

## VACUUM HOSE REEL SER. 881

---

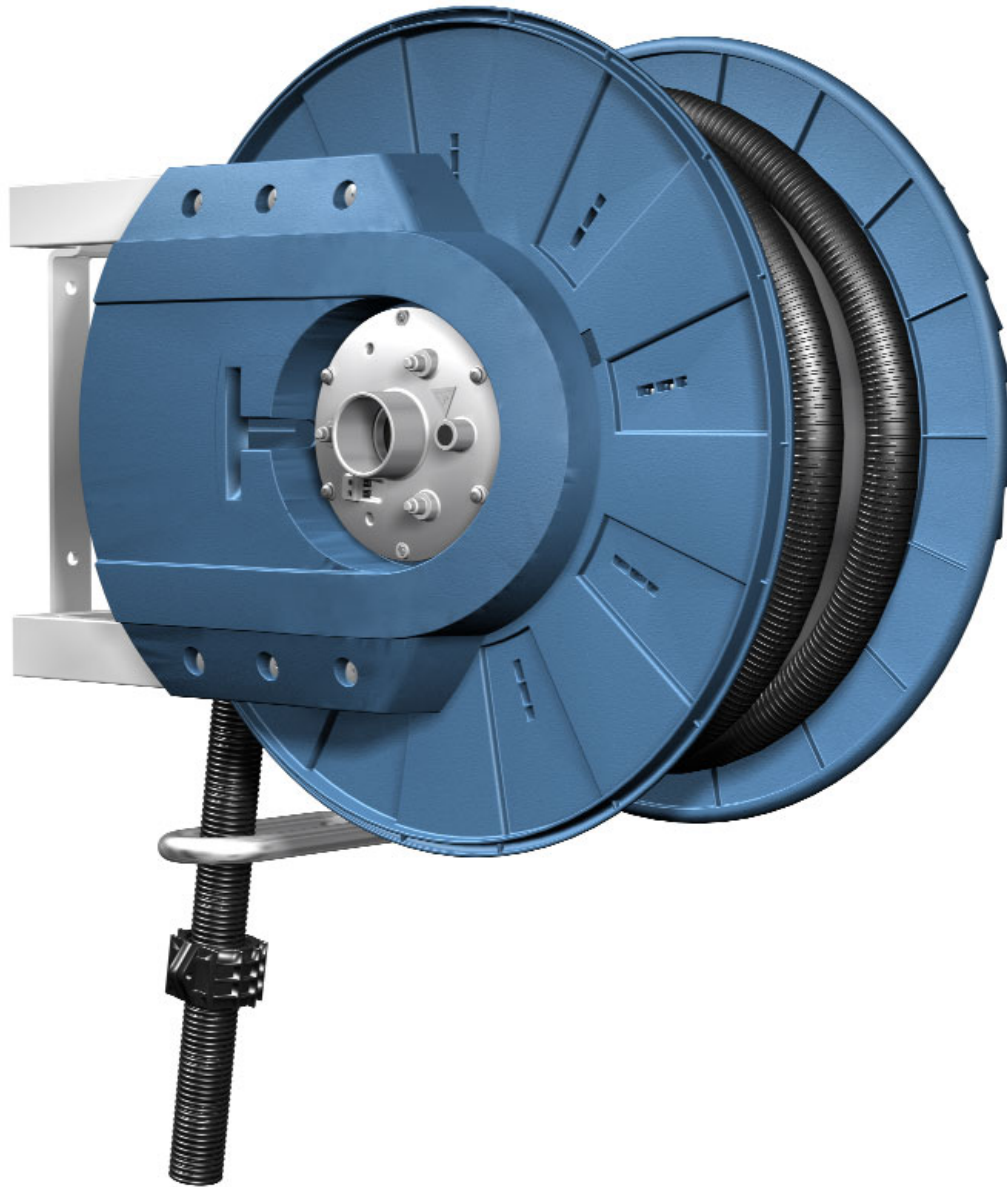

---

**FOR SAFE HOSE STORAGE AND  
REDUCED WEAR AND TEAR**

*Improving your workspace*

# VACUUM HOSE REEL SER. 881

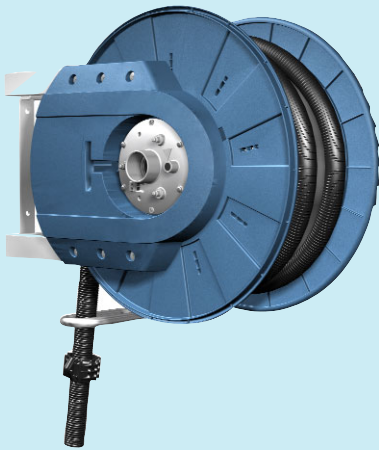

**Ser. 881 Hose Reel for Vacuum, a practical solution to an annoying problem.**

When scattered across the floor, all uncoiled hoses are untidy, awkward and hazardous. A floor free from hoses offers many advantages.

The risk of tripping is almost eliminated, it looks nice and tidy and it reduces wear and tear.

A vacuum hose not being used, is best stored on a retracable reel. It means easy access for forklifts, carts and other and shows general good house keeping.

The vacuum hose reels are suitable for use with centralized or mobile high vacuum systems.

Additional to vacuum cleaning, typical applications are extraction of welding fumes and particles from grinding and polishing.

- Available as standard with or without hose.
- Full recoil of the hose length (10m).
- Ratchet function to lock the hose in desired out-drawn position.
- Strong and robust design.
- Comes complete with automatic valve and micro-switch.
- Maintenance free.

## Model range

Medium	Max negative pressure	Hose dimensions				Part No. With hose	Part No. Without hose
		Int.diam. mm	Int.diam. (in)	Length m	Length (ft)		
Vacuum	45 kPa (7 psi)	38	(1 1/2")	10	(33)	30805081	30804981
	45 kPa (7 psi)	50	(2")	10	(33)	30804881	30804981

The outlet side of the vacuum hose reel shall be connected to the pipe-work by anti-static type of vacuum hose Ø63 mm. (Not supplied with the reel).

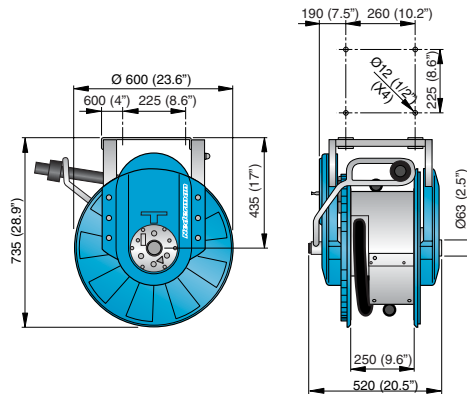

### Accessories:

For the wide range of accessories please look in the Nederman Product Catalogue, High Vacuum.

**Material recycling:** 100% of the weight.

**Net weight:** including hose on hose reel 28 kg

The majority of Nederman's products are manufactured within ISO 9001 and ISO 14001-certified system.

Rights reserved for modification of design and measurements.

Manufacturer:

**AB Ph. Nederman & Co**  
Sydhamnsgatan 2  
SE-252 28 Helsingborg  
Sweden

E-mail: support@nederman.se  
Tel.: Int. +46 42 18 87 00  
Fax: Int. +46 42 14 79 71  
www.nederman.com

**Nederman**<sup>®</sup>  
Improving your workspace